

Global Change Effects on the Michigan Forest Ecosystem and Productivity.

By: Tom Hurst, Ring Lardner Middle School, Niles Community Schools, Niles Michigan

Grade/Subject: 8th grade Woodworking

Unit Overview

A schedule change at Ring Lardner Middle School has created an opportunity to integrate core curriculum content standards into the woodworking curriculum. We have noticed a steady deterioration of wood quality that is used for building student projects. We build a chairs of Southern Yellow Pine (SYP) and ash. The early wood of our SYP has been getting progressively wider. This appears to effect wood strength. We also are in an area that has been infested with the emerald ash borer and it is effecting our wood supplies.

By studying the effects of increased CO₂ on tree growth and the impact of the emerald ash borer we are answering questions that affect our everyday activities in the woodworking program and address benchmarks in the Michigan core curriculum for science, social studies and math.

It is our intent that students will appreciate the role of science, math and social studies topics in solving or understanding real world applications faced in their daily activities. We also hope to produce quantifiable data to evaluate the strength of wood products we use to build furniture.

Essential questions:

- Is the Michigan forest resource sustainable in light of known threats of climate change, air quality issues, and exotic species threats.
- Is global change real in the great lakes region and the world? Can we show data to prove climate change is occurring? Is the species composition changing in our area?
- Is wood structure/strength affected by global change?

Cross Curricular connections

Science	Constructing and reflecting on scientific knowledge Photosynthesis and plant physiology Carbon Cycle Climate and weather observations Ecosystems and eco regions Human effects on the atmosphere Movement of exotic species, changes in ecosystems, succession Physical science application, simple machines
Social Studies	Human and environmental impacts Geographic perspectives
Mathematics	Charting mathematical data Applying ratios to physical models Measurement in English and Metric systems.

Resources

- Climate Change and Michigan EPA 230-F-97 008v, September 1997

- Changes in Lake Ice: Ecosystems response to global change. Teaching issues and experiments in ecology, http://tiee.ecoed.net/vol/v3/issues/data_sets/lake_ice/students.html
- Michigan natural features inventory, county and state maps and descriptions, Michigan State University Extension. <http://web4.msue.msu.edu/mnfi/data/veg1800.cfm>
- Atmospheric carbon dioxide study. Keeling. <http://cdiac.esd.ornl.gov/trends/co2/sio-mlo.htm>
- Center for exotic species at MTU. <http://forest.mtu.edu/research/ces/> Assorted pages.
- <http://www.emeraldashborer.info/>
- The Bugmobile lesson plan. Invasive species, Pennsylvania DCNR <http://paipm.cas.psu.edu/pdf/invspecies.pdf>
- http://web1.msue.msu.edu/reg_se/roberts/ash/ MSU Extension EAB web links
- The Cost of Cool. Video, Available from: The Video Project, 45 Lusk Alley, San Francisco, CA 94107. (415) 821-7200.

Teaching and Learning objectives

- Students will locate and utilize global and local data resources to evaluate climate change.
- Students will identify global change threats to the forest ecosystems in Michigan from multiple sources.
- Students will develop an understanding of the impacts of human consumption patterns.
- Students will investigate the results of plant growth on wood strength as affected by global change.
- Students will develop an appreciation for the role of academic subjects in the industrial education woodworking curriculum.

MI Content Benchmarks addressed.

Science.

Constructing new scientific knowledge C L1,3,5 MS

1. Generate scientific questions about the world based on observation.
3. Use tools and equipment appropriate to scientific investigations.
5. Use sources of information in support of scientific investigations.

Reflecting on Scientific Knowledge R II 1

Well spread throughout benchmarks

1. Evaluate the strengths and weaknesses of claims, arguments, or data.
5. Develop an awareness of and sensitivity to the natural world.

Ecosystems LEC III.5

All students will investigate and explain how communities of living things change over a period of time:

3. Predict the effects of changes in one population in a food web on other populations.

EAW V.3 Atmosphere and weather

All students will analyze the relationships between human activities and the atmosphere:

4. Explain the impact of human activities on the atmosphere and explain ways that individuals and society can reduce pollution. (HS standard)

Social Studies

II, Geographic Perspectives

Content Standard 2: All students will describe, compare, and explain the locations and characteristics of ecosystems, resources, human adaptation, environmental impact, and the interrelationships among them. (Human/Environment Interaction)

4. Explain how humans modify the environment and describe some of the possible consequences of those modifications.

V. Inquiry

Content Standard 2: All students will conduct investigations by formulating a clear statement of a question, gathering and organizing information from a variety of sources, analyzing and interpreting information, formulating and testing hypotheses, reporting results both orally and in writing, and making use of appropriate technology.

2. Gather and analyze information using appropriate information technologies to answer the question posed.
3. Construct an answer to the question posed and support their answer with evidence.

Activities

1. Exotic species in Michigan and the great lakes region, threats and opportunities.
2. Mining data for global climate change. seeking and applying research data.
3. Where do we go from here, how do we manage our environment to minimize human impact on the forest? What adaptations will we need to make to face global change?
4. Measuring the effects of global change on wood strength,

Activity 1: Exotic Species: Opportunities and threats.

Teacher will bring in examples of local common invasive species: Garlic mustard, multi-floral rose, zebra mussel, autumn olive, purple loosestrife, spotted knapweed, emerald ash borer (dead), sea lamprey or others that are readily available.

With students identify samples and discuss their impacts. Ask what other problem species they know.

- Explain the emerald ash borer problem. Show samples of tree infestation and images of dead trees, share the numbers from the Detroit area, discuss our small pocket problem. (*many counties in SW Michigan affected, as of July 2005 spreading into Ohio, Indiana and pockets of N. Michigan. Local infestation in Berrien county, Came in on nursery stock, refer to emerald ash borer updates on MSUE website*)
- Discuss how the borer is spread. (*Movement of firewood and affected nursery stock, flight range under 1 mile, control by removal of all ash within flight zone from infected areas.*)
- Move to computer lab and Google emerald ash borer. Have students search for images, maps and regulations on its transport. Suggest MDA, and MSUE
- Discuss the devastation caused by the loss of the American Chestnut and elm. Show images of urban neighbor hoods before and after Dutch elm disease. Discuss the devastation to rural areas with the loss of the chestnut regarding wood, and nut crops. (*Elm was a major urban shade tree, tough wood, handles, heavy furniture, barn beams. Chestnut: high quality wood, major nut producer important as rural livestock feed, shade tree, large crown area in forest*)
-
- Revisit the uses of Ash from lesson one. What are the possible impacts of complete loss of the white-ash. (*loss of specialized wood product ;baseball bats, tool handles, bent wood items, chairs, baskets, snowshoes, sleds, oak alternative in furniture, shade tree in urban areas.*)
- Discuss the movement of exotic species and the cost of control vs. the costs of prevention.
- Do a schoolyard walk and identify with the students exotic species in yards, flower beds, and weed areas. Most of our weeds are European and Asian. (*Use set of weed cards available from extension office. Look for gypsy moth, Asian ladybug, earthworms, lambsquarter, dandelion, garlic mustard, multi-floral rose or other local problems*)
- Complete the Invasive species work sheet in class. (*Information to be from schoolyard walk, home experiences and class presentation. If computer lab is available also by web searches*)

Activity 2

Using existing data to demonstrate global climate change.

Seeking and applying research data.

What is the evidence of global climate change?

- In class discussion, student opinions, is climate change a problem, do we have any solid evidence that changes are occurring?

(Students brainstorm based on their own ideas or stories from others. Possibilities include; less snow, hotter summers, less wildlife... What can we use for solid evidence of climate change?)

- What is the difference between climate and weather?

(Climate long term measure of the typical conditions of an area. Examples normal temperatures, typical frost free days, average seasonal rainfall. Weather is what is happening in the short term. Example it is raining now.)

- How long do we need to measure the weather to see a climate change?

(Opinions from students, discuss dry vs wet years. Refer to the summer of Mount St. Helens. Are these climate measures?)

Global climate change investigation using scientific research.

- Students Google Keeling. And select site <http://cdiac.esd.ornl.gov/trends/co2/sio-mlo.htm>

Analyze CO₂ data, discuss seasonal variations, why Hawaii?

(Hawaii is an isolated area, normal season changes, shows a steady increase)

- Where does CO₂ come from?

(By product of burning of fossil fuels and plant products, by product of fertilizer manufacturing, natural decomposition of organic material and animal respiration.)

- Students load Lake Mendota Ice Data activity,

http://tiee.ecoed.net/vol/v3/issues/data_sets/lake_ice/students.html This unit is to be team taught with math or science teacher so students further see the connection between industrial arts, math and science.

- Follow the student instructions for the activity. Teacher provides printed instructions for each student.

(This is very well presented on the web site. Student and teacher data sets. Teacher should complete activity prior to students to be completely familiar with operation)

- Graphing on Excell with provided data. Spreadsheet assistance as needed.

- Have students Google Glaciers Global warming and quickly peruse images and articles using receding ice sheets as evidence of increasing arctic and alpine temperatures.

(Alaska, Glacier National Park, Alps in Europe, Ice shelves in Antarctica, Arctic ice cover, Greenland)

Evaluation. Students write a two minute paper. Topic: Is global warming real, can we prove it?

- *(Refer to activities in TIEE Lake Ice web site)*

Activity 3

Where do we go from here, how do we manage our environment to minimize human impact on the forest? What adaptations will we need to make to face global change?

- Thinking globally, working locally philosophy
- Consumer habits: Show The Cost of Cool
- Use questions and activities from the curriculum guide for the video. (evaluation)
- Bring in copies of electric, oil and gas bills. Show students how to read kilowatts, gallons and therms of energy used. Hand out a home energy consumption data sheet and have them complete for homework.
- Have students complete a carbon calculator worksheet then move to the computer lab and use the carbon calculator at <http://www.americanforests.org/resources/ccc/>
- Complete a carbon calculator for the school based on annual energy expenditures, secure data from school business office. Impress upon the students the need to save energy at school.
- Share the results of the Aspen FACE experiments from Wisconsin and the Loblolly pine FACE experiments in North Carolina.
- What are the effects of increased CO₂ on tree growth?
- Show tree cookies from fast grown and slower grown trees.
- Discuss the offsets of Ozone on plants/trees. (Refer to Aspen FACE)
- Is increased CO₂ a good thing?

Activity 4

Measuring the effects of global change on wood strength.

Teacher preparation

- This unit requires specific application of materials unique to a skilled woodworker or lumberman. Materials must be accurately prepared to control external variables to the activity.
- Secure Southern Yellow pine 2 x 8 or greater planks from a local lumberyard. Select for a wide range of ring density visible on the end of each plank. This will be obvious. Blanks that have the late wood rings tangential to the wide face will be easier to prepare for testing blanks.
- Blanks are easily ripped on the tablesaw with the rip fence.
- Blanks may be sorted for ring angle or a skilled sawyer can cut a bevel to achieve a true quarter-sawn sample. (see drawings)
- This activity will require a testing fixture. A sample fixture is drawn in this packet

Student procedure

- Prepare data sheets for each team of students.
- Student teams will take turns testing 5 samples each. Ring width should vary within each team.
- Each sample will be weighed, an average ring width will be calculated and grain orientation identified. Each team will check and record for their samples.
- After all samples are tested the data may be charted with excel as specified in the procedure below.
- Class data will be merged and sorted. Compiled results will be charted.

An investigation of the shear strength of pine lumber as it relates to ring density.

What is the effect of increased wood growth per growing season on the shear strength and deflection in quarter sawn loblolly pine lumber?

Statement of the problem.

It appears from anecdotal sources that lumber strength is decreased in rapidly grown trees with wide spacing between annual rings. We are curious if this will affect the size of materials needed to safely construct our light-weight furniture projects.

This faster growth can be from a variety of causes including: Natural or supplemental fertilization, increased levels of CO₂, insect and weed control, greater tree spacing, available soil moisture, increased growing season and other less obvious factors.

For the purpose of this middle school investigation we will limit the study to wood from one species of tree from one region where the lumber shows a wide difference in tree growth rates.

Hypothesis

Wood produced from rapidly growing southern yellow pine (loblolly pine) will have diminished shear strength as compared to slower growing wood from the same species.

Limitations

This investigation will only take into account ring density. The causes may only be hypothesized as to soil, air quality or other growth issues.

Procedure.

Wood samples will be cut from air-dried Loblolly pine Obtained through the local lumber yard. Grade stamps will be checked for region of origin if possible. Samples will be 3/8" x 1" x 15"

- All samples selected for testing will be quarter-sawn with a ring angle of less than 10 degrees off perpendicular to face. Samples will be selected and labeled by the number of rings shown on the end or each piece. Sorting and grouping will be based on the available samples.
- It is predicted that earlywood widths will range from 3 – 12mm Samples outside this range will be discarded. Samples including knots will also be discarded
- Samples will be oven dried to 8% or less moisture content.
- Testing will be by rigidly clamping sample to surface with ½ of the sample extending off the table. Sample will be flat on the table with the width parallel to the floor. The fulcrum point will be crisp with a 1/8" radius edge.
- A padded "C" clamp will serve as the contact point for attaching the load. Clamp will be applied with center of pad ½" from end. Weight will be applied through the clamp.
- Weight may be applied by hydraulic force with a pressure meter or by adding weights to a suspended bucket with a 5 – 1 ratio lever arm. Weights will be of a known value. For middle school students the use of the lever system is preferred to also teach simple machines and ratios.
- Weight will be added to the point of wood failure or destructive testing.
- Process will be replicated with at least 5 samples for each group.
- Results will be recorded on teacher prepared record sheets. Data to be recorded will be weight application to cause failure and deflection prior to failure.
- Results will be graphed with rings per inch on the X axis and weight application on Y axis.

Applications of knowledge.

Students will use the data to select materials for mass produced beach chairs we make in class. This can be used for lumber selection prior to sawing of parts. Also we can use the data to justify to our supplier the need to pre-select the wood for our uses. Students can also justify a premium price for superior quality materials.

The data will be shared with the math teachers to be used in statistics and probability investigations.

Ultimately students will recognize that changes to the forest products industry due to global change may have an effect on the characteristics of solid wood lumber and the shift to engineered wood products. Also we can stress the environmental consequences of insisting on the desired characteristics of old growth lumber as we cut our remaining old growth forests.

Applications for further study.

Repeat tests with knotted lumber to demonstrate weakness of knots and grain run-out.

Repeat test with flat sawn lumber realizing the results will vary widely.

Repeat with other species.

Set up investigation to test compression strength of wood samples.

Follow up to activity

After testing and data analysis we will discuss implication for increased tree growth on wood strength. From the data we should be able to determine a point of diminishing returns that can be used to guide optimal tree growth rates for strength.

References

Lecture notes: Global Change Teacher Institute, Dr. Bill Holmes, Dr Andrew Burton, Elevated CO₂, O₃, General Climate Change.

Dr. Andrew Burton, side conversation on the application of municipal sludge to Douglas Fir forests and resulting loss of wood quality.

FACE study, Effects of elevated CO₂ and O₃ on carbon sequestration in Aspen

USDA Forest Products Laboratory, Measurement of Earlywood and Latewood Properties in Loblolly Pine. 04/2005. <http://www.fpl.fs.fed.us/documnts/techline/early-late-wood.pdf>

Larson, P. R., Kretschmann, D. E., Clark III, A., Isenbrands J. G. 2001. Juvenile wood formation and properties in southern pine. Gen. Tech. Rep. FPL-GTR-129, Madison, WI, U.S. Department of Agriculture, Forest Service, Forest Products Laboratory. 42 p.

Kretschmann, D.E., Cramer, S.M., Lakes, R. Schmidt, T. 2005. Selected Mesostructure Properties in Loblolly Pine from Arkansas Plantations. In: Douglas D. Stokke and Leslie H. Groom, eds. Chapter 12, Characterization of the Cellulosic Cell Wall. Blackwell Publishing, Ames, Iowa.

Sample testing apparatus

- Use a sturdy lab table.
- Counter weights can be book or students.
- Drawing is not to scale to accommodate fit.
- Pole to rope 1 unit.
- Rope to load 5 units.
- 3 meter lever arm is sufficient.
- Will yield a 5:1 ratio on lever.
- Pad under load is required.
- Sample is centered on 1/8" radius.
- Use 100 gram weights to start until range is determined.

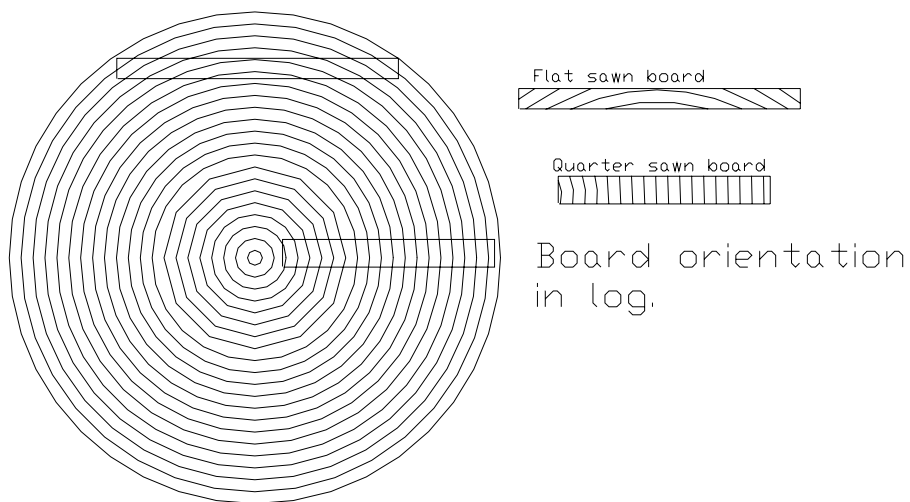
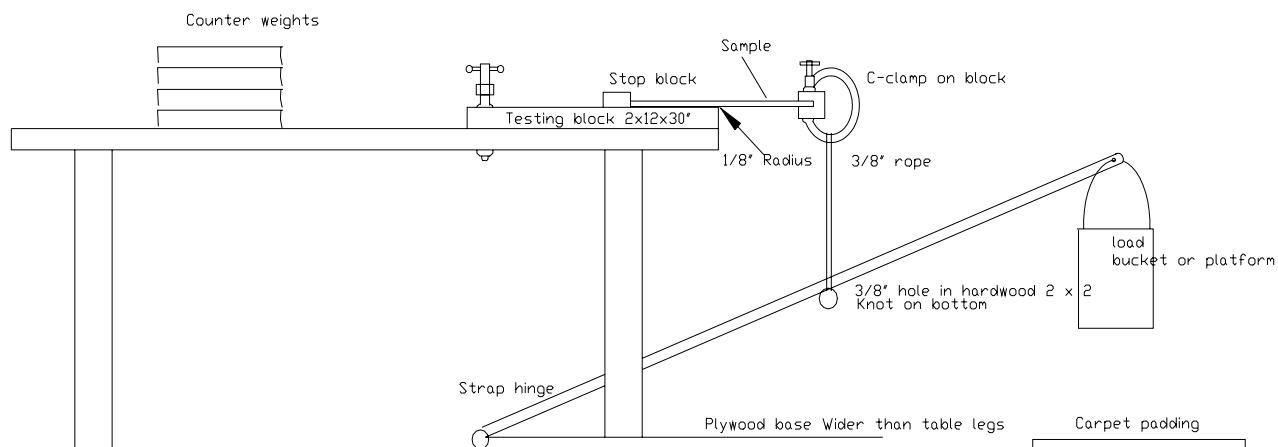

Final Evaluation

In groups of three students will complete a storyboard poster on one of the following topics

- Effects of increased Carbon Dioxide on plants
- An invasive specie that affects my life directly is...
- When I use electricity at home the power comes from ...
- What does cool/trendy really cost?
- When I am 45 years old and gas costs \$20 per gallon ...
- In 2106 the trees in my woods will be...

Storyboard must contain at least:

- One mathematically derived chart.
- One map showing change or concentrations.
- 4 pictures
- Information from at least 5 sources

The topic heading must be readable from 20 feet.

The information presented must be convincing and research based. This is not a science fiction activity.

Students will present the information on their storyboards and answer question from their classmates.

Storyboards will be displayed in the hall and selected entries will be submitted to the Berrien County Arts and Sciences EXPO.

Invasive species

Name _____

Hour _____

1. What is meant by the term "invasive species"?
2. Give three examples of an invasive species.
3. How might invasive species get here?
- 4.. What human activities might encourage the spread of invasive species?
5. How can the emerald ash borer be harmful?
6. How can invasive species be harmful to native species?
7. How could invasive species cost us money?
8. What can you do to help prevent invasive species from arriving here?

NWF1

The Cost of Cool Video and Educator Resource Guide Order Form

Three easy ways to order!

- 1.) **Fax** your completed order form to (703) 438-6468, Attention: Kristin Hayes.
- 2.) **Call** Kristin Hayes, Assistant Coordinator for High School Programs, at 1-800-247-7387 ext. 6393.
- 3.) **Mail** your completed order and payment (checks payable to "The Video Project") to:

Kristin Hayes
National Wildlife Federation
11100 Wildlife Center Dr.
Reston, VA 20190

Part 1: Shipping Information

Name _____
Title _____
Grades Taught _____ Subjects Taught _____
School/Org. Name _____
Address _____

City, State, Zip _____
E-mail Address: _____

Yes! Please sign me up for NWF's **free** High School Programs e-Newsletter.

Part 2: Order Information

Please send me ____ copies of *The Cost of Cool* video and Educator Resource Guide. The entire package is just \$95 each, plus shipping and handling. (Promotional code: NWFCOC02)

The Cost of Cool video and Educator Resource Guide \$95

Shipping and Handling --- --- \$9.95

Total --- ---

Part 3: Billing Information Same as Shipping Information

Name (as appears on your credit card) _____
Address _____
City, State, Zip _____
Credit Card Type: _____ Card Number: _____
Expiration Date: _____ Authorization Signature: _____
(Promotional code: NWFCOC02)